

Inexpensive LASER modulator

This is a good project to demonstrate how to transmit audio signals (music) over a beam of light using a Laser pointer. By varying the battery voltage to a laser pointer, you *amplitude modulate* the laser light. This circuit uses the least expensive laser pointer I could find at Staples (approx \$5). I used the headphone output of a CD player as the input to the modulator. Connect the modulator circuit output across the battery inputs (with batteries removed) of the laser pointer. When connecting to the laser pointer, make sure that you solder your wire *after* the push-button, otherwise you will have to hold the laser pointer push button to operate. Once attached, you may have to adjust the 7 volt external power supply and audio levels to obtain the clearest sound.

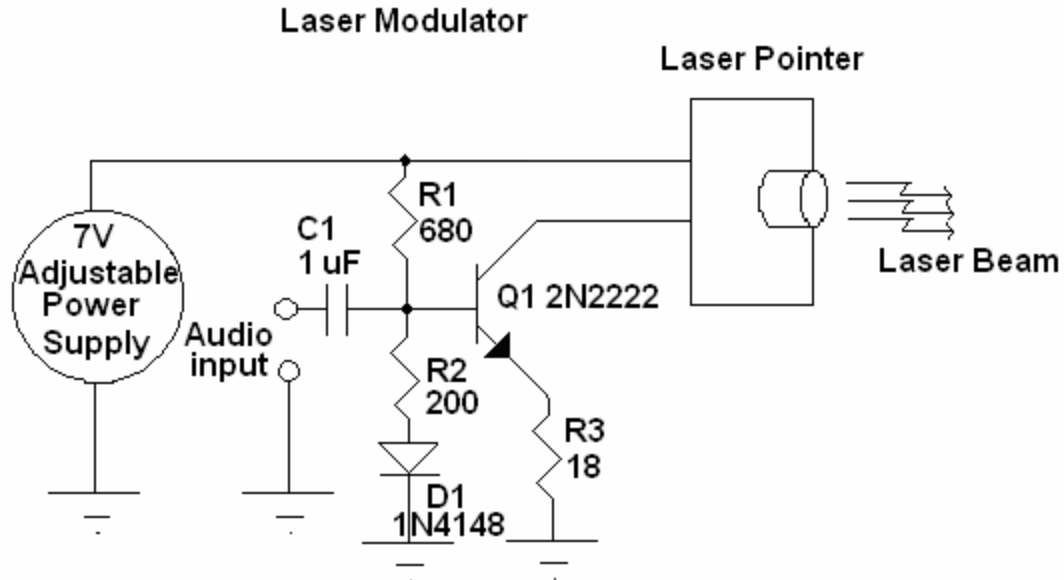

The receiver side uses a solar cell I bought from Radio Shack. The amplitude modulated beam of light from the laser pointer will produce a varying voltage signal that tracks the audio signal from the CD player. The output from the solar cell is enough to drive the *line in* to most amplifiers directly, but for added gain, add this pre-amp circuit.

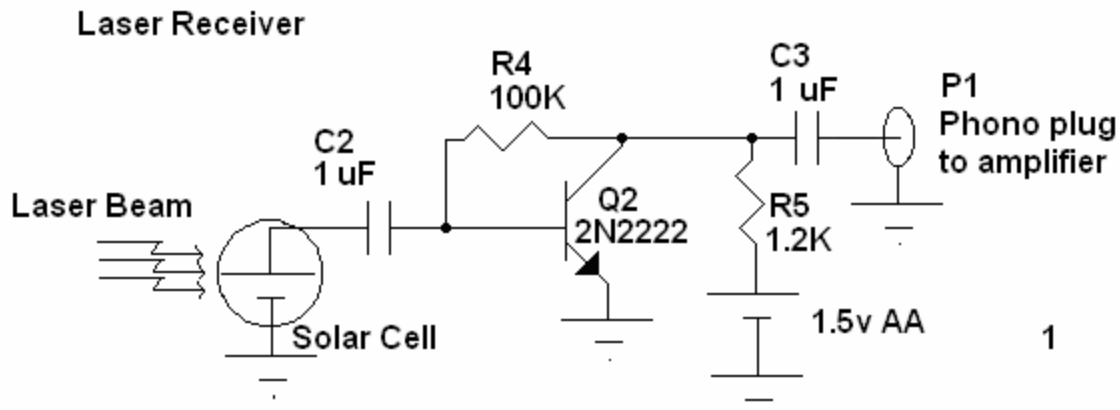

Note: As with all laser light, please exercise proper caution.

Don Marzewski
Visteon
2750 Morris Rd.
Lansdale, PA. 19446
(610-584-7062)
dmarzews@visteon.com

Modulator

	Description	Allied #
R1	680 ohm	832-0330
R2	200 ohm	832-0243
R3	18 ohm	296-5526
D1	1N4148	431-0614
Q1	2N3904	431-0406
C1	1 uF	881-5274
Z1	Laser Pointer	

Pre-amp

	Description	Allied #
R4	100K	296-5610
R5	1.2K	296-5564
Q2	2N3904	431-0406
C2	1 uF	881-5274
C3	1 uF	881-5274
B1	Solar Cell	
B2	1.5 volt AA battery	774-0200
P1	Phono plug	283-0016