

The PUMPKIN LIGHT LED



By Mark McCuller

Email: mcculler@mail.com

The PUMPKIN LIGHT LED

By: Mark McCuller

DESIGN SUMMARY

The Pumpkin Light LED is a battery-powered device that illuminates the inside of the pumpkin. The pumpkin light LED produces a flicker that resembles that of a flame that produces a spooky feel and an irresistible glow that draws your eyes to the pumpkin. (See Figure # 1) The LED light will shine through the pattern or holes cut into the pumpkin that can be seen from the outside of the pumpkin. The pumpkin light LED produces an interesting flame effect that makes the pumpkin come to life with an awesome spectacle of uniqueness never seen before. The timer circuit produces a Pseudo-random timer pattern that makes a LED flickering to simulate that of a flame. With the two ultra bright Orange LED's flickering in a random pattern inside, the pumpkin is illuminated brightly on the outside.

DESIGN PURPOSE

The Pumpkin Light LED is designed to make the illumination of a pumpkin safer without the use of a flame, to prevent fires and burns. The LED light will make the pumpkin glow with an orange flickering glow that gives the pumpkin an interesting effect.

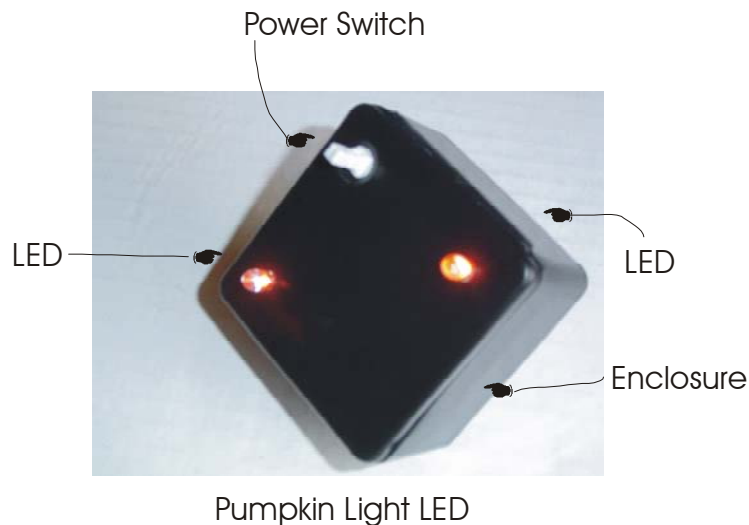

Figure #1 Pumpkin Light LED

TECHNICAL DESCRIPTION

The NAND Schmitt trigger MC14093 (On-Semiconductor) gate can be used as a simple astable timing circuit as shown in any digital electronics book. The Schmitt trigger basic operation works when the input voltage reaches a specified voltage level, the output changes states. Thus when the input goes below another specified voltage level the output will return to the original state. Because of this action we can make this IC a timer by the use of a resistor and a capacitor. In the schematic (Figure # 4) for the Pumpkin Light LED the circuit works as follows: The voltage charges the capacitor coming from the High output of the NAND gate until it has reached the threshold voltage value. When this threshold is reached the Input A, B is High thus the Output of the NAND gate is now Low. When the discharge voltage threshold is reached, Input A, B is Low and this makes the Output High once again, thus charging the capacitor up again. (See truth table in Figure # 3) The NAND gate will keep on repeating this cycle of charging and discharging to produce a square wave timing frequency. The NAND gate produces a square wave pulse frequency that can be adjusted by lowering or raising the values of the capacitor and/or resistor to change the frequency output of the NAND gate. The Resistor and Capacitor (RC) values determine the timing frequency of the RC circuit. (See Figure # 2 for RC frequency equation)

The output of the NAND gate goes through a limiting resistor (680 ohm) that bias the base of BJT transistor 2N2222 to turn the transistor on/off at the frequency of the RC NAND circuit. The transistor is used as an on/off switch to turn the LED on/off to produce the simulated flame effect. The Common Emitter configuration's output goes through the switching diode 1N4148 to maintain positive current direction going to the LED that turns on and off the Orange LED. The Ultra Bright Orange LED's produce a simulation of a flame flickering that is adjustable by the trim pots R13, R14, R15, and R16. An alternative use is the "One LED Option" shown on Figure 3 of the schematic. Connect point A and point B wire together to (One LED Option) point 3, noted on schematic Figure # 2. The LED's numbers #1 and # 2 are not used in the single LED option.

$$F = \frac{1}{R \times C}$$

Figure # 2 RC Frequency

TRUTH TABLE

INPUT A	INPUT B	OUTPUT
0	0	1
0	1	1
1	0	1
1	1	0

Figure # 3 NAND Schmitt Truth Table

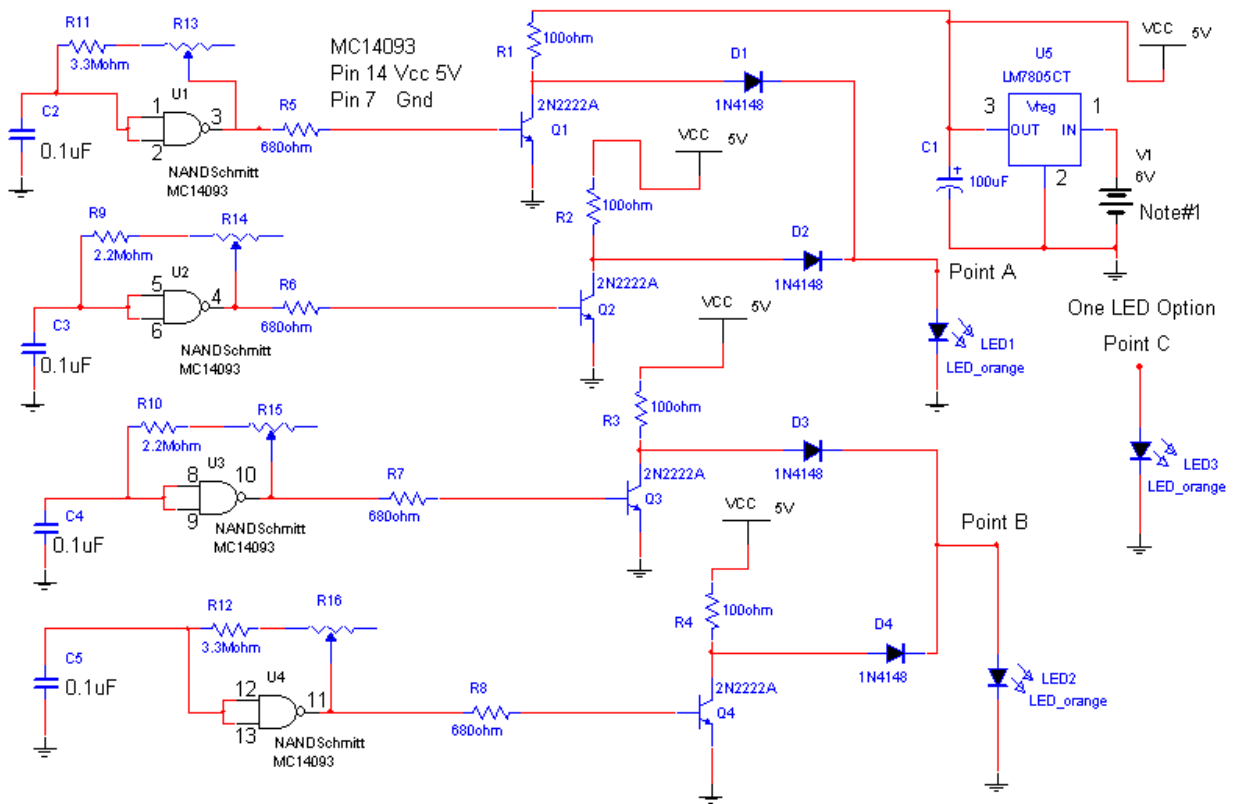

Figure # 4 Pumpkin Light LED Schematic

Note #1 in Schematic: The battery power can come from 4 batteries at 1.5V or two 9V batteries wired in parallel for more current and makes the Pumpkin light LED last longer.

The LM7805 voltage regulator will reduce the voltage of the 6v or 9v battery to 5vdc level to power the components and the LED's. To produce the brightest light output we are limiting the current through the 100-ohm resistor (R1, R2, R3, and R4) connected to the collector on the transistor. This 100-Ohm resistor can be adjusted to raise or lower the current going into the LED. The current to the LED is around 20mA in a pulsed form due to the flashing on off cycle. The Orange LED from Allied Electronics produces a brightness level of around 12,000MCD.

You can use different colors of LED to produce different effects. Red, Yellow, and White LED's produce excellent results also. The brightest LED you can purchase will work the best.

DESIGN DETAILS

The construction of the Pumpkin Light LED is as follows. The parts list is shown in Figure #6. There are two options in powering the Pumpkin Light LED. One is using the 4" C" size batteries with an external power wire going outside the pumpkin to a battery pack. The second powering option is to use two 9V batteries and wire them in parallel to produce more current that will make the Pumpkin Light LED operate for a longer time. Wire and solder in the components as shown on the proto board layout as shown in Figure # 7. Note that the adjustable frequency trim pots R13, R14, R15, and R16 are soldered on the front side of the proto board. This orientation will provide for future adjustment of the flickering rate of the LED's. You will have to determine with an ohmmeter the two pins on the power switch that provide the on/off condition. The power switch can be mounted to external wire for design movement flexibility. The LED's can be soldered into the proto board for mounting or soldered to 20-AWG wires. This flexibility will make assembly easier in locating the LED and power switch on the front cover of the enclosure. Caution do not look directly into the Ultra Bright LED's

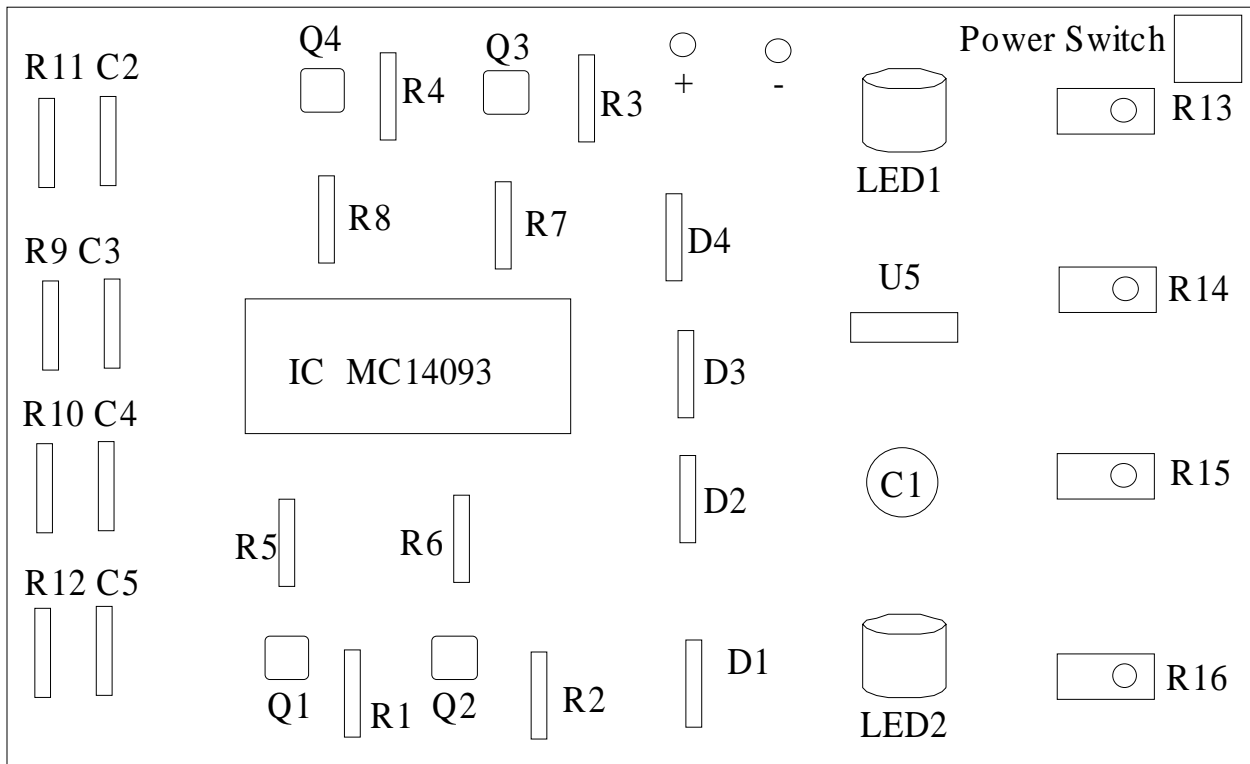

Protoboard Layout View
Figure # 7 Layout

Amount	Parts Description	Allied Part #
1	Quad 2 input NAND Schmitt MC14093BCP	568-3021
1	LM7805 Voltage Regulator +5vDC	288-0001
4	1N4148 Diode	263-1538
2	Orange Ultra Bright 5mm LED	505-9712
4	2N2222 Transistors NPN	248-1004
1	Switch On-Off	855-1059
1	Enclosure Plastic 3x2.5x1.5	736-7404
1	Battery Holder 4 "C" Size Batteries	839-0336
2	Batteries "C" Size Alkaline 2 per Pack Total=4	737-0997
4	Capacitor Ceramic 104, 0.1uF	881-3486
1	Capacitor Electrolytic 100uF	852-7029
4	Trimmer Resistors 2Meg	754-2719
2	Resistors 2.2Meg 1/4W Cordon Film	832-0907
2	Resistors 3.3Meg 1/4W Carbon Film	832-0912
4	Resistors 680Ohm 1/4W Carbon Film	832-0330
4	Resistors 100Ohm 1/2W Carbon Film	832-9004
1	Pressboard 0.1"x0.1" Spacing	237-0119
1	DIP Socket 14Pin	512-4691
1	18-2 Stranded Power Wire 5ft	Miscellaneous
1	Plastic Drywall anchor screw	Miscellaneous
NOTE:		
	9V Battery Option	
1	9V Battery Alkaline 2 per pack	737-0999
2	9V Battery Straps	839-3094

Figure # 6 Parts List

Pumpkin Light LED Mounted Inside Pumpkin



Figure # 7 Pumpkin Lights LED's in Use

DESIGN ASSEMBLY

When you finished soldering the circuit board together cut the proto board to size to fit inside the enclosure housing. Test the circuit to make sure the circuit is working correctly and you can adjust the flickering rate of the LED's. To install the enclosure cover you will need to drill the holes for the LED's, power switch, and the 4 trim pots adjustment screws that matched the proto board layout. Glue in place with silicone glue the externally mounted LED's and Switches if option used. Secure the circuit board to the top of the enclosure cover with silicone glue. While the glue is drying you can tape the items in place with duct tape and remove when glue is dry. Mount the plastic screw on the bottom of the enclosure housing. If you used the External power option you will need to drill a hole on the side of the bottom housing to run the power feed out. The plastic mounting screw will allow the unit it to be screwed into the pumpkin for operation and use. See Figure # 8 for illustrated use. The plastic screw is optional in simplifying the mounting and use of the Pumpkin Light LED. Install the 9v Batteries if you used this power option. Put the enclosure assembles top and bottom together and install it into your pumpkin for use. Adjust the flash rate of the LED's to produce the desired flame effect.

Mounting Screw



Side View



Back View

Figure # 8 Pumpkin Light LED

CONCLUSION

Install the Pumpkin Light LED into your pumpkin and enjoy the spooky feel and an irresistible glow that draws your eyes to it and the interesting flame effect that makes the pumpkin come to life with an awesome spectacle of uniqueness never seen before. Sent me an email mcculler@mail.com and let me know what you think of the Pumpkin Light LED idea. Enjoy...