

## Computer Controlled Cannon

Edward A. Nauman

In my quest for a more spectacular 4th of July entertainment, I came up with a computer controlled, propane/oxygen fueled cannon. The end result is a "party favor" capable of producing an acoustic sound pressure level (SPL) of 180+ decibels or roughly the equivalent of a couple of sticks of dynamite. I used a 330 cubic foot nitrogen tank for the barrel. After cutting off the bottom, I welded a support for the axle, propane and oxygen tanks, and mounts for the 24 Volt batteries. The valve was removed and the opening welded shut then drilled and tapped for a 14mm spark plug. The fuel is fed in to the end near the spark plug through 2 solenoid valves and stainless steel tubing. There is an anti-flashback check valve in each line to prevent any flame from being forced back up the lines. These check valves can be obtained from any welding supply house. The electronics consist of a microcontroller and support circuitry. In addition there is an instrumentation amplifier to condition the signal from the high intensity microphone mounted in the end of the barrel. The hand held remote control has a thumbwheel switch to set the amount of time the gas is loaded thereby controlling the sound level. Also mounted on the remote is an LCD display that reads out the SPL in decibels. To operate, the user clears the area, opens the gas valves, turns on the battery power to the electronics and selects the charge on the remote control. There are 2 modes of operation. In the manual mode, the fire control

button is pressed and released to load the gas. A warning light on the barrel flashes during the load and becomes steady when the load is complete. The fire control button is pressed again to detonate the charge. In the auto mode, the charge set by the thumbwheel switch is loaded and detonated immediately when the load is complete. The thumbwheel is calibrated in seconds. This device is capable of breaking windows at 100 feet or more so finding a place to aim it must be given careful consideration. It will permanently destroy human ears if pointed at someone. It is not a toy and must be treated with the respect one gives dynamite. No one should be standing closer than 25 feet BEHIND the device when operated. On holidays when the dogs are barking at the bottle rockets being lit in the neighborhood, it only takes one shot from the cannon and there won't be a dog barking the rest of the evening.

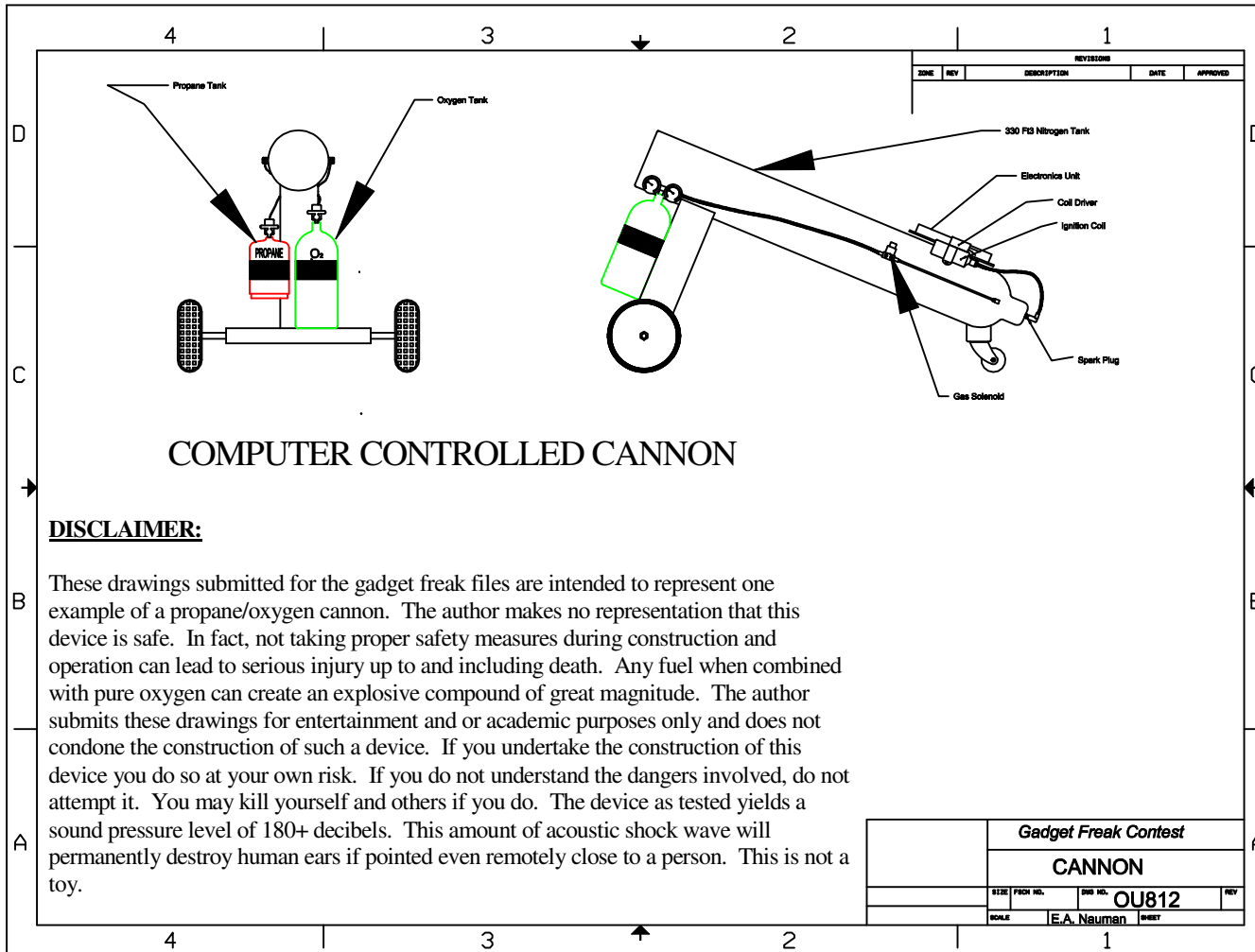

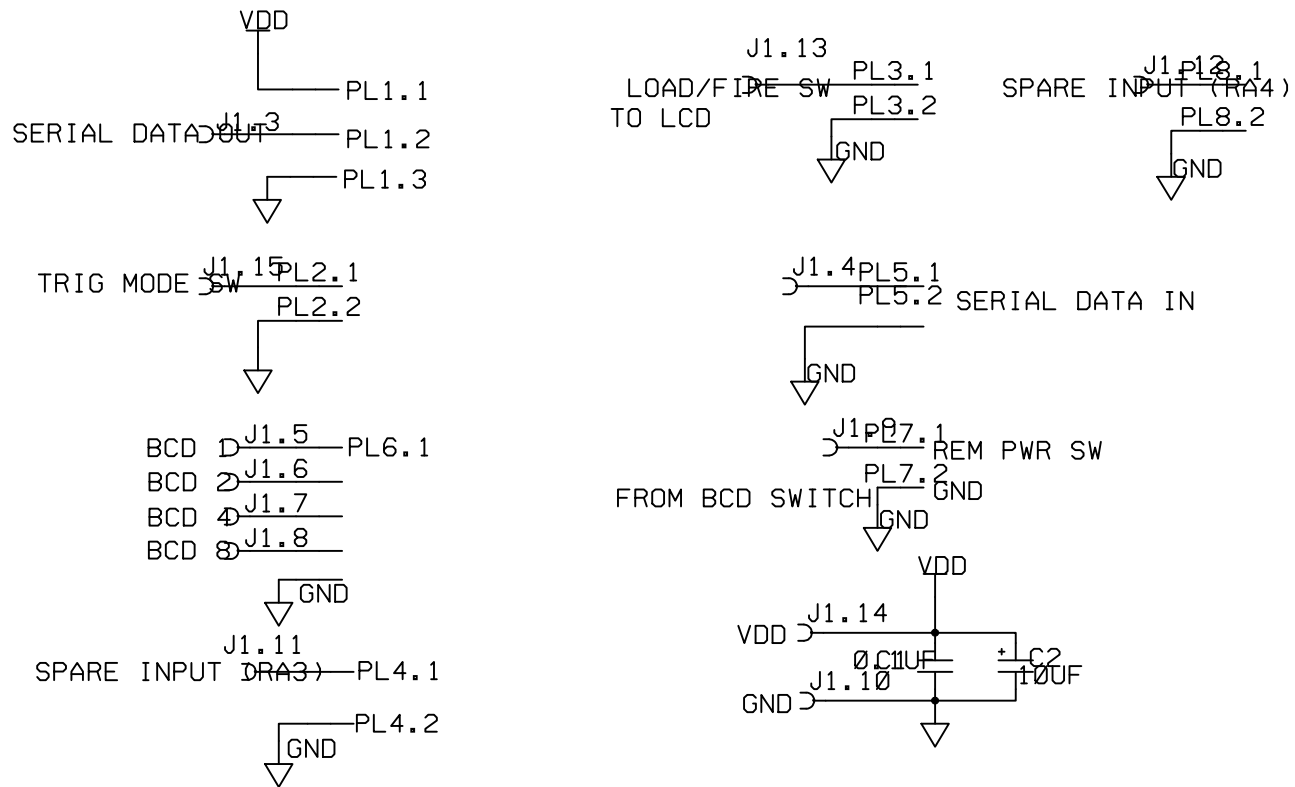

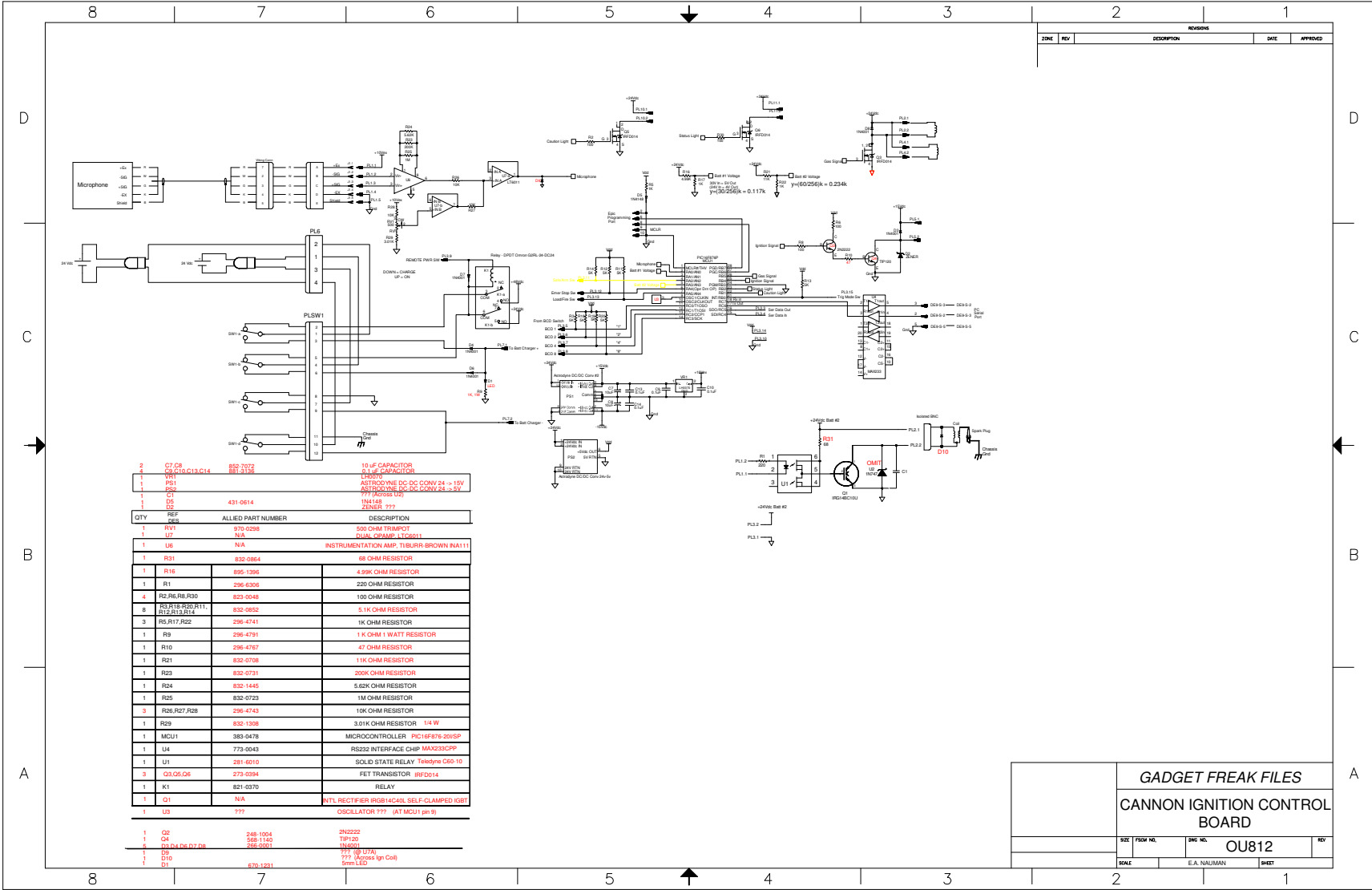

QTY	REF	ALLIED PART NUMBER	DESCRIPTION
2	C7,C8	882-2702	10 µF CAPACITOR
1	W1	882-1306	0.1 µF CAPACITOR
1	R51	439-0000	100Ω RESISTOR
1	R52	439-0000	100Ω RESISTOR
1	C1	431-0614	500 OHM TRIMPOT
1	D2	194-1000	1N4148 DIODE
1	U6	NA	INSTRUMENTATION AMP. T1UBURR-BROWN INA111
1	R31	832-0864	68 OHM RESISTOR
1	R16	895-1396	4.99K OHM RESISTOR
1	R1	296-6306	220 OHM RESISTOR
4	R2,R6,R8,R30	823-0048	100 OHM RESISTOR
8	R3,R18,R20,R11, R12,R13,R14	832-0832	5.1K OHM RESISTOR
3	R5,R17,R22	296-4741	1K OHM RESISTOR
1	R9	296-4791	1 K OHM 1 WATT RESISTOR
1	R10	296-4767	47 OHM RESISTOR
1	R21	832-0708	11K OHM RESISTOR
1	R23	832-0731	200K OHM RESISTOR
1	R24	832-1445	5.62K OHM RESISTOR
1	R25	832-0723	1M OHM RESISTOR
3	R26,R27,R28	296-4743	10K OHM RESISTOR
1	R29	832-1308	3.01K OHM RESISTOR 1/4 W
1	MCU1	383-0478	MICROCONTROLLER PIC16F876-20I/SP
1	U4	773-0043	RS232 INTERFACE CHIP MAX232CPE
1	U1	281-6010	SOLID STATE RELAY Teklynx C60-10
3	Q3,Q5,Q6	273-0394	FET TRANSISTOR IRFD14
1	K1	821-0370	RELAY
1	C1	NA	NTL RECTIFIER P80B14C4L SELF-CLAMPED IGBT
1	U5	???	OSCILLATOR ??? (AT MCU1 pin 9)
1	C2	848-1004	2N2222
1	Q4	568-1140	TIP120
4	D3,D4,D6,D7,D8	356-0501	1N4001
1	D5	???	5V 50 D7A
1	D10	???	10V (200mA) 10V C40
7	D11	870-1231	5mm LED

<b>GADGET FREAK FILES</b>			
<b>CANNON IGNITION CONTROL BOARD</b>			
REV	NO.	DATE	APPROVED
1	1		
SIZE	FRGM NO.	DRG NO.	REV
		OU812	
SCALE	E.A. NAUMAN		DWHT